

DETAIL A  
SCALE 1:8

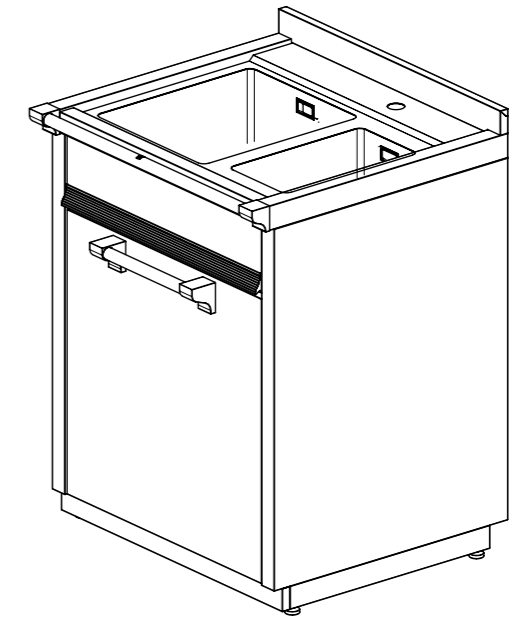
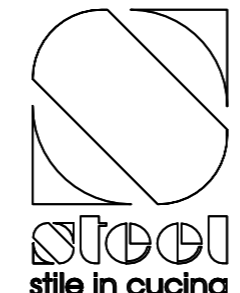

CLASSE DI TOLLERANZA MEDIA PER DIMENSIONI LINEARI								
DIMENSIONI mm	da 0,5 a 3	da 3 a 6	da 6 a 30	da 30 a 120	da 120 a 400	da 400 a 1000	da 1000 a 2000	da 2000 a 4000
TOLLERANZA mm	±0.1	±0.1	±0.2	±0.3	±0.5	±0.8	±1.2	±2

NUM	DATA	MODIFICA	ESECUTORE		
3					
2					
1					
DESCRIZIONE / DESCRIPTION		CODICE/CODE		REV.	NR.PZ.
		<b>Complemento Ascot A7S-L2</b>		-	-
				MATERIALE/MATERIAL	
RIF. CLIENTE/CUSTOMER'S RE.		RIF. FORNITORE/SUPPLIER'S RE.		TRATTAMENTO/PROCESS	
-		-		-	
DISEGNATORE/EDITOR		APPROV.		DATA/DATE	SCALA
Raffaele		-		23/02/2017	1:10
				MASSA/MASS kg	-
<small>Proprietà della STEEL S.p.A. CARPI (MO). Senza l'ormale autorizzazione scritta della stessa il presente disegno non potrà essere utilizzato per la costruzione dell'oggetto rappresentato né venire divulgato o riprodotto, la proprietaria tutela i propri diritti a rigore di legge.</small>					